

ROOF FANS WDH

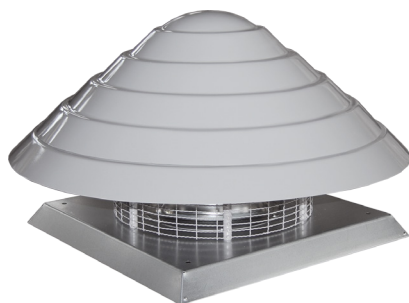

- I. CONTACTS
- II. ORIGINAL INSTRUCTION MANUAL
- III. WARRANTY TERMS AND CONDITIONS
- IV. UNIT STARTUP REPORT
- V. INSPECTION AND MAINTENANCE DOCUMENT
- VI. SERVICE NOTIFICATION
- VII. LIST OF SUBASSEMBLIES INSTALLED IN THE UNIT



Please read this instruction manual carefully before beginning any work.

I. CONTACTS



Szymański, Nowakowski General Partnership
31 Lubelska Str., 08-500 Ryki
POLAND

phone +48 81 883 56 00,
fax +48 81 883 56 09
info@juwent.com.pl
www.juwent.com.pl

Export department

mob.+48 502 087 841
mob.+48 664 465 243
export@juwent.com.pl

II. ORIGINAL INSTRUCTION MANUAL

ROOF FANS WDH size 31 to 63

SPIS TREŚCI

1. INTENDED USE	5
2. OPERATION CONDITIONS	5
3. DESIGNATIONS	5
4. DEVICE DESCRIPTION	5
5. TECHNICAL DATA	6
6. ADDITIONAL EQUIPMENT	9
7. TRANSPORT	13
8. SAFETY RECOMMENDATIONS	13
9. MOUNTING	14
10. ELECTRICAL INSTALLATION	14
11. AUTOMATION ELEMENTS	15
12. DEVICE COMMISSIONING	19
13. REPAIR, MAINTENANCE AND WITHDRAWAL FROM USE	19
14. REMOVING MALFUNCTIONS	20
15. INFORMATION	20

1. INTENDED USE

WDV fans comply with the EU energy efficiency requirements for fans and ventilation systems. They are high-performance fans with excellent air efficiency as well as enhanced noise level control and air flow adjustability according to current needs.

WDH fans with horizontal airflow are designed for use in locations where continuous mechanical ventilation is required, e.g. in production halls, warehouses, retail centres, shops, offices, etc.

The concentrations of corrosive vapours and gases or particulates in the exhaust air should not exceed the acceptable limits specified by environmental regulations.



The temperature of the air being removed cannot be more than 55°C.



Use of the fans in explosion-hazard atmosphere is not admissible.

2. OPERATION CONDITIONS

WDH fans are provided with the following motors:

- » (AC/4J) single-phase asynchronous with five-step transformer speed control for sizes 31; 35; 40, 45 and 50;
- » (AC/4T) three-phase asynchronous with five-step transformer speed control for sizes 31; 35; 40; 45; 50, 56 and 63.
- » (EC/J) single-phase electronically commutated for sizes 31; 35; 40, 45;
- » (EC/T) three-phase electronically commutated for sizes 35; 40; 45; 50, 56 i 63.

3. DESIGNATIONS

Roof fan	WDH - -
Size	31; 35; 40; 45; 50; 56; 63
Motor type	AC/4J – asynchronous, single-phase, four-pole; AC/4T – asynchronous, three-phase, four-pole; (EC/J) single-phase electronically commutated (EC/T) three-phase electronically commutated

4. DEVICE DESCRIPTION

Types of roof fans WDH – fans with horizonatal airflow – 7 sizes from 31 to 63.

Components:

- » High-performance rotor made from high-strength composite materials and provided with an integrated electric motor;
- » Enclosure manufactured in laminate;
- » Bases made of galvanised steel sheets.

The fans are designed for installation on PU or PUT (with sound insulation) universal bases.

5. TECHNICAL DATA

Basic dimensions

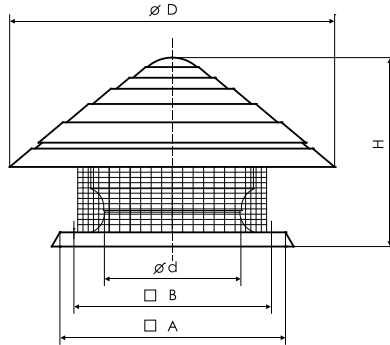

Fan type	$\varnothing d$ [mm]	$\square A$ [mm]	$\square B$ [mm]	$\varnothing D$ [mm]	H [mm]	Weight (AC motor) [kg]	Weight (EC motor) [kg]
WDH-31	231	552	480	675	401	16,5	17,5
WDH-35	258	552	480	855	468	22	23,0
WDH-40	298	632	560	855	491	26,5	26,0
WDH-45	331	702	630	855	530	40,0	30,5
WDH-50	366	782	710	1220	568	51,0	46,0
WDH-56	408	782	710	1220	603	54,5	49,5
WDH-63	454	872	800	1220	642	74,0	55,5

Ambient parameters for the fan and the motor (for all sizes)

Air temperature range	Max. air humidity	Max. dust content	Motor parameters	
			IP	Insulation class
to + 50°C	90%	5 mg/m ³	54	F

WDH roof fans with AC motors parameters

Fan type	Impeller type	Voltage [V]	Motor power [kW]	Current [A]	Speed [rpm]
Three-phase motors					
WDH-31	RH31V-4DK.2F.VR	400	0,21	0,50	1390
WDH-35	RH35V-4DK.4C.VR	400	0,33	0,68	1380
WDH-40	RH40V-4DK.4I.VR	400	0,54	1,20	1290
WDH-45	RH45V-4DK.6F.VR	400	1,00	1,95	1370
WDH-50	RH50V-4DK.6K.VR	400	1,45	2,80	1280
WDH-56	RH56V-4DK.6N.VR	400	2,50	4,60	1330
WDH-63	RH63V-4DK.7Q.VR	400	3,90	6,60	1270
Single-phase motors					
WDH-31	RH31V-4EK.2F.VR	230	0,22	1,10	1370
WDH-35	RH35V-4EK.4F.VR	230	0,37	1,85	1390
WDH-40	RH40V-4EK.4I.VR	230	0,58	2,60	1270
WDH-45	RH45V-4EK.6K.VR	230	1,10	5,20	1380
WDH-50	RH50V-4EK.6N.VR	230	1,65	7,40	1350

WDH roof fans with three-phase AC motors parameters operating noise level

Fan type	Noise level [dB(A)]											
	At the air outlet side*				At the air outlet side**							
	Working point 1 at the distance of		Working point 2 at the distance of		Fans on PU bases				Fans on PUT bases			
					Working point 1 at the distance of		Working point 2 at the distance of		Working point 1 at the distance of		Working point 2 at the distance of	
	1 m	5 m	1 m	5 m	1 m	5 m	1 m	5 m	1 m	5 m	1 m	5 m
WDH-31	55	41	58	44	56	50	59	53	44	38	47	41
WDH-35	59	45	61	47	60	54	62	56	48	42	50	44
WDH-40	61	57	63	49	62	56	64	58	50	44	52	46
WDH-45	65	51	67	53	66	60	68	62	54	48	56	50
WDH-50	66	52	69	55	67	61	70	64	55	49	58	52
WDH-56	68	54	72	58	69	63	73	67	57	51	61	55
WDH-63	69	55	75	61	70	63	76	70	58	52	64	58

WDV roof fans with single-phase AC motors parameters operating noise level

Fan type	Noise level [dB(A)]											
	At the air outlet side*				At the air outlet side**							
	Working point 1 at the distance of		Working point 2 at the distance of		Fans on PU bases				Fans on PUT bases			
					Working point 1 at the distance of		Working point 2 at the distance of		Working point 1 at the distance of		Working point 2 at the distance of	
	1 m	5 m	1 m	5 m	1 m	5 m	1 m	5 m	1 m	5 m	1 m	5 m
WDH-31	55	41	57	43	56	50	58	52	44	38	46	40
WDH-35	58	44	60	46	59	53	61	55	47	41	49	43
WDH-40	61	47	63	49	62	56	64	58	50	44	52	46
WDH-45	66	52	68	54	67	61	69	63	55	49	57	51
WDH-50	65	51	67	53	66	60	68	62	54	48	56	50

* noise level in dB(A) – sound pressure level of the air outlet side in free field, taking into account the directional factor ($Q = 2$) and the distance from the fan (R), as specified in the table;

** noise level in dB(A) – sound pressure level of the air inlet side, taking into account the room noise absorption capacity ($A = 100\text{m}^2$), the directional factor ($Q = 2$) and the distance from the fan (R), as specified in the table.

WDH roof fans with EC motors parameters

Fan type	Impeller type	Voltage [V]	Motor power [kW]	Current [A]	Speed [rpm]
Three-phase motors					
WDH-35	RH35V-ZIK.DC.VR	400	1,50	2,4	2430
WDH-40	RH40V-ZIK.DC.VR	400	1,3	2,1	1840
WDH-45	RH45V-ZIK.DC.VR	400	1,10	1,8	1450
WDH-50	RH50V-ZIK.GG.VR	400	3,10	5,0	1770
WDH-56	RH56V-ZIK.GG.VR	400	2,6	4,2	1410
WDH-63	RH63V-ZIK.GG.VR	400	2,10	3,4	1090
Single-phase motors					
WDH-31	RH31V-6IK.BD.VR	230	0,56	2,8	2100
WDH-35	RH35V-ZIK.DC.VR	230	0,98	5,0	2090
WDH-40	RH40V-ZIK.DC.VR	230	0,84	4,2	1580
WDH-45	RH45V-ZIK.DC.VR	230	0,64	3,3	1220

WDH roof fans with three-phase EC motors parameters operating noise level

Fan type	Noise level [dB(A)]											
	At the air outlet side*				At the air outlet side**							
	Working point 1 at the distance of		Working point 2 at the distance of		Fans on PU bases				Fans on PUT bases			
	1 m		5 m		Working point 1 at the distance of		Working point 2 at the distance of		Working point 1 at the distance of		Working point 2 at the distance of	
	1 m	5 m	1 m	5 m	1 m	5 m	1 m	5 m	1 m	5 m	1 m	5 m
WDH-35	72	58	74	60	73	67	75	69	61	55	63	57
WDH-40	68	54	70	56	69	63	71	65	57	51	59	53
WDH-45	65	51	68	54	66	60	69	63	54	48	57	51
WDH-50	73	59	76	62	74	68	77	71	62	56	65	59
WDH-56	69	55	73	59	70	64	74	68	58	52	62	56
WDH-63	67	53	70	56	68	62	71	65	56	50	59	53

WDH roof fans with single-phase EC motors parameters operating noise level

Fan type	Noise level [dB(A)]											
	At the air outlet side*				At the air outlet side**							
	Working point 1 at the distance of		Working point 2 at the distance of		Fans on PU bases				Fans on PUT bases			
	1 m		5 m		Working point 1 at the distance of		Working point 2 at the distance of		Working point 1 at the distance of		Working point 2 at the distance of	
	1 m	5 m	1 m	5 m	1 m	5 m	1 m	5 m	1 m	5 m	1 m	5 m
WDH-31	64	50	67	53	65	59	68	62	53	47	56	50
WDH-35	65	51	67	53	66	60	68	62	54	48	56	50
WDH-40	65	51	67	53	66	60	68	62	54	48	56	50
WDH-45	60	46	66	52	61	55	67	61	49	43	55	49

* noise level in dB(A) – sound pressure level of the air outlet side in free field, taking into account the directional factor (Q = 2) and the distance from the fan (R), as specified in the table;

** noise level in dB(A) – sound pressure level of the air inlet side, taking into account the room noise absorption capacity (A = 100m²), the directional factor (Q = 2) and the distance from the fan (R), as specified in the table.

6. ADDITIONAL EQUIPMENT

For roof fans WDV additional equipment can be delivered:

- » roof bases;

additional elements;

Fan type	Roof base size		Additional elements			
			Assembly plate	Self-closing damper	Inlet diffuser	Flexible connector
31	PU-4	PUT-4	PM-4	SWD-4	DW-4	KEO-4
35	PU-4	PUT-4	PM-4	SWD-4	DW-4	KEO-4
40	PU-5	PUT-5	PM-5	SWD-5	DW-5	KEO-5
45	PU-6	PUT-6	PM-6	SWD-6	DW-6	KEO-6
50	PU-7	PUT-7	PM-7	SWD-7	DW-7	KEO-7
56	PU-7	PUT-7	PM-7	SWD-7	DW-7	KEO-7
63	PU-8	PUT-8	PM-8	SWD-8	DW-8	KEO-8

Elements necessary for assembling the WDH fans

- » PU universal bases;
- » PUT universal noise damping bases.

Additional elements supplied for the WDH fans

- » PM assembly plates;
- » SWD self-closing damper
- » DW inlet diffusers;
- » KEO flexible connectors.

PU Universal base (for all the types of fans)

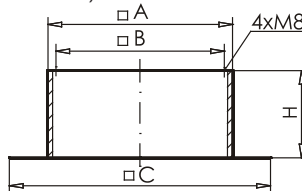

Base size	□ A [mm]	□ B [mm]	□ C [mm]	H [mm]	Weight [kg]
PU-4	512	480	812	300	17
PU-5	592	560	892	300	19
PU-6	662	630	962	300	16
PU-7	742	710	1042	300	22,5
PU-8	832	800	1132	300	25

PUT universal noise damping roof base (for all the types of fans)

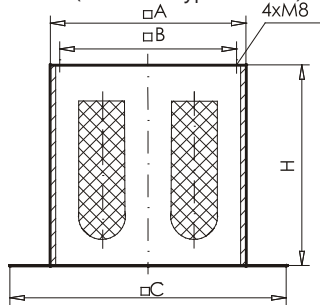

Base size	□ A [mm]	□ B [mm]	□ C [mm]	H [mm]	Weight [kg]
PUT-4	512	480	812	700	34
PUT-5	592	560	892	900	47,5
PUT-6	662	630	962	900	54,5
PUT-7	742	710	1042	900	60,5
PUT-8	832	800	1132	900	71,5

Efficiency of universal base noise damping is in the A scale ~14dB(A).

Assembly plate PM (for all the types of fans)

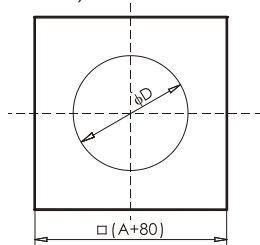

Assembly plate size	□ A [mm]	ØD [mm]	Weight [kg]
PM-4	512	450	2,5
PM-5	592	500	4,5
PM-6	662	560	5
PM-7	742	630	6
PM-8	832	710	7

Inlet holes can have any shape: round, square, rectangular. In case of round holes we recommend to use the diameter equal with the diameter of mounted fan. It will permit to keep the air flow velocity in the hole ~5 do 8 m/s.

KEO flexible connector (for all the fan types)

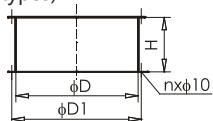

Connection size	ØD [mm]	ØD1 [mm]	H [mm]	n	Weight [kg]
KEO-4	450	480	110	8	1,9
KEO-5	500	530	110	8	2,1
KEO-6	560	590	110	8	2,4
KEO-7	630	660	110	8	2,7
KEO-8	710	740	110	8	3

SWD Self-closing damper (for all the types of fans)

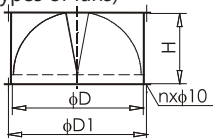

Air damper size	ØD [mm]	ØD1 [mm]	H [mm]	n	Weight [kg]
SWD-4	450	480	255	8	5,5
SWD-5	500	530	270	8	6,5
SWD-6	560	590	300	8	7,5
SWD-7	630	660	335	8	9,5
SWD-8	710	740	375	8	11,5

Inlet diffuser DW (for all the fan types)

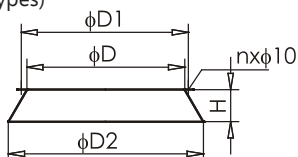

Diffuser size	ØD [mm]	ØD1 [mm]	ØD2 [mm]	H [mm]	n	Weight [kg]
DW-4	450	480	554	90	8	3,0
DW-5	500	530	616	100	8	3,8
DW-6	560	590	689	112	8	4,2
DW-7	630	660	775	126	8	4,6
DW-8	710	740	874	142	8	5,8

In case of sloped roofs the variation of the universal bases marked PUs and universal universal noise damping roof bases marked PUTs can be used above the ceilings.

PUTs bases differ from PUT bases with additional elements to support the base on sloped roof and with collar. In the bottom part enabling connecting with the duct placed between PUTs base and the ceiling.

PUTs base is a PUTs base without dampening plate.

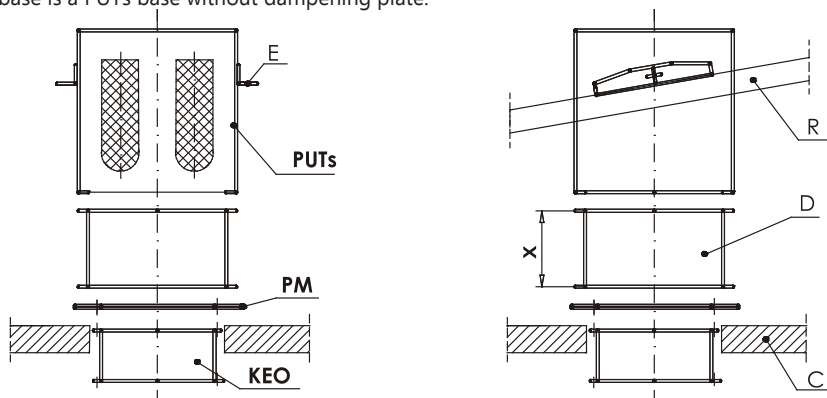

E - elements for supporting the base on the roof

KEO -flexible connector

D - duct

X – duct section made on site and of the length determined during assembling – it's function is to extend the base to the ceiling and supporting it.

PM - assembly plate

R - roof

C - ceiling

PUTs universal noise damping roof base (for all the fan types).

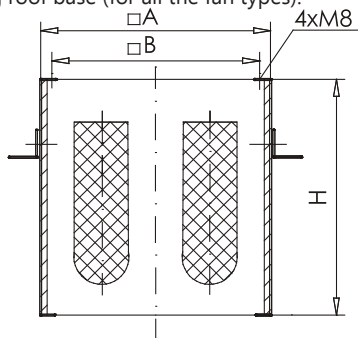

Base size	□ A [mm]	□ B [mm]	□ C [mm]	H [mm]	Weight [kg]
PU _s -4/PUT _s -4	512	480	812	700	21,5/29
PU _s -5/PUT _s -5	592	560	892	900	30,5/47,5
PU _s -6/PUT _s -6	662	630	962	900	34,5/53,5
PU _s -7/PUT _s -7	742	710	1042	900	38,5/59
PU _s -8/PUT _s -8	832	800	1132	900	43,5/73,5

PUTs Universal base - PUTs without noise damping plates.

The rest of the additional equipment elements are the same as for the PU and PUT universal bases.

7. TRANSPORT

Fans are delivered as completely assembled, protected against pollutions and weather with polyethylene foil or cardboard box.

The fan is delivered with the Product Book.

The PU and PUT roof bases are additional equipment and are delivered separately protected with polyethylene foil.



The fans should be transported on one level so as to prevent any mechanical damages.



The contents of the packaging should be checked immediately after delivery and in case of non-compliance inform the supplier of fans or Juwent company.

8. SAFETY RECOMMENDATIONS



Roof fans should be used in accordance with the operation manual.



Installation, connection, commissioning, inspection and repair works on the fans should be performed by an authorised technician, and electrical works by a person holding the required qualifications.

All maintenance and repair works should be carried out with voltage off



In the case of the fan failure immediately turn the motor electrical power supply off.



The fan can only work with properly operating electrical protection devices. It must be uninterruptedly connected to the electrical installation fitted with protection terminal, residual-current device and service switch.



Use original spare parts only.

Due to its design, the device does not emit any hazardous radiation.

Despite the fact that the device has been designed and manufactured in accordance with the standards valid as for the moment of the manufacture start, probability of injury and damage to health when using the device is unavoidable. This probability is related to frequency of using, cleaning and repairing the device, presence of persons within the danger area, and not respecting the safety rules as set out in the instruction.

Severity of the bodily injury and deterioration of health is dependant on numerous conditions which can be foreseen partially only by considering them when designing the device and by providing descriptions and warnings in the instruction manual.

Therefore residual risk is present if recommendations and instructions are not respected by the operator.

9. MOUNTING

The fans are bolted trough seals on roof bases, ventilation ducts or damping roof bases with use of M8 bolts.

The fans should be installed upright.



Installation of the fan and additional equipment should conform to the construction design covering the manner of placing and the fan whilst taking into consideration strength of the roof structure and tightness of the roofing.



Connection ducts at the fan suction side should have their own supports and mountings.

THE ADDITIONAL EQUIPMENT LISTING

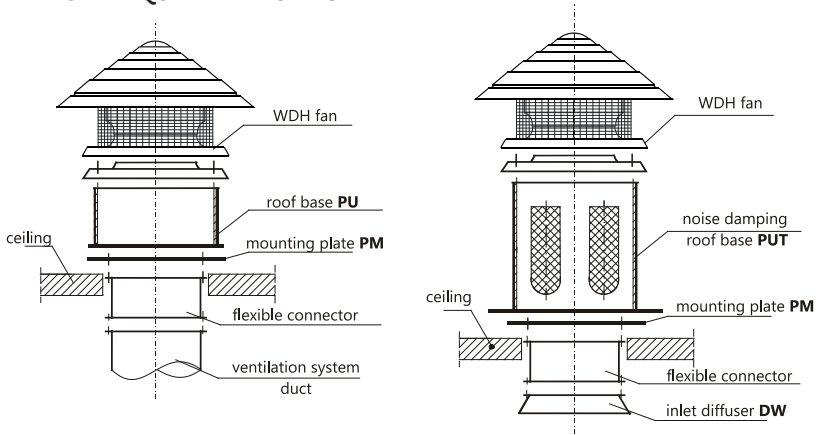

10. ELECTRICAL INSTALLATION

Connections of electrical installation and power supply to the fans must be carried out in accordance with relevant construction standards and regulations.



Electrical connections to the fans can only be carried out by an authorized electrician familiar with the instruction manual.

Before connecting make sure that the voltage and frequency rating of the power supply are in accordance with the data given on the fans data plates. Otherwise, do not connect the device.

The electrical connection of the fan itself should be carried out taking into account the service switch located directly by the fan, as well as the overload and short-circuit protection inside the power supply/control box.

Warning! Make sure to provide the required motor protections, otherwise the warranty is void.

The fans are equipped with three-phase (3~400V/50Hz) or single-phase motors (1~230V/50Hz) which should be power-supplied with the voltage from the main switchgear fitted with main circuit-breaker and differential protection.

Each fan comprises a TK thermal protection system for motor with external connection to the control system. The thermal protection stops the fan in case of irregularities in the operation (increased temperature on the winding). This allows for long and safe operation of the fan.

Example of electrical diagrams - Fig. 1 to 2.



Lack of connection of thermal protection, overload protection and short-circuit protection of the motor will void the warranty.

In case of any operations performed on the fan, disconnect the unit from the mains, even if the fan is not running (thermal protection can restart the engine, causing rotation of the impeller).

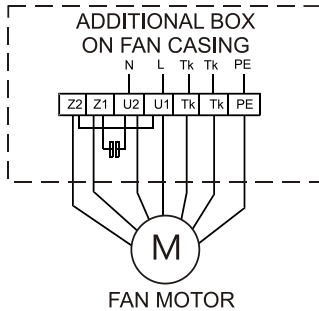

FAN MOTOR WIRING DESIGNATIONS:

- U1 - brown
- U2 - blue
- Z1 - black
- Z2 - orange
- Tk - white

Fig. 1. Example electric connection diagram of WDV roof fans with single-phase motors.

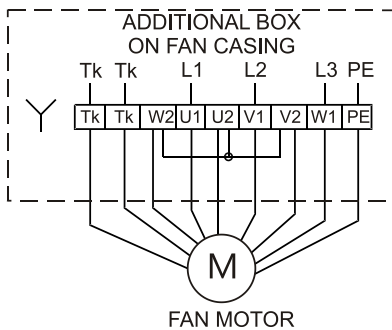

FAN MOTOR WIRING DESIGNATIONS:

- U1 - brown
- U2 - red
- V1 - blue
- V2 - grey
- W1 - black
- W2 - orange
- Tk - white

Fig. 2. Example electric connection diagram of WDV roof fans with three-phase motors (only star connection).

11. AUTOMATION ELEMENTS

The fan can be fitted with the following:

- **ZS-... [-1;-2;-3;-4]/1 power supply/control boxes** - designed to control 230VAC single-phase and three-phase (single speed) fans. The box should be supplied from the main switchgear equipped with the main switch breaker and differential protection.

DESIGNATIONS

Control box

ZS-1 | 1

Number of connected units 1; 2; 3; 4

Unit type 1 - single-phase, three-phase one speed

- **Transformer speed controllers:** Five-speed transformer speed controllers allow for quiet and economical operation. They have a 5-position (with the switch located on the housing) transformer output voltage regulation. Controllers of this type are present in single and three phase versions, with 1 or 2 switches) in several sizes with different nominal current value.

Transformer speed controllers (single and three phase) in version with two switches allow selection of one of the available speeds for each of the switches. The choice of the switch is carried out remotely via the contact switch (from an external device: a clock timer, detector).

Single phase single switch ARW speed controllers

Type	ARW-1,2	ARW-3	ARW-5	ARW-7	ARW-10
Voltage [V]	230	230	230	230	230
Current [A]	1,2	3	5	7	10
Protection level	30	30	30	30	30
Height [mm]	128	148	155	155	255
Width [mm]	77	96	145	145	147
Depth [mm]	71	91	145	145	155
Voltage and current levels U[V]/I[A]	115/0,9 135/1 155/1,1 180/1,2 230/1,2	115/2,4 135/2,6 155/2,8 180/3,0 230/3,0	80/4,0 105/4,3 135/4,6 170/5,0 230/5,0	80/6,0 105/6,3 135/6,6 170/7,0 230/7,0	80/6,5 105/7,5 135/8,5 170/10 230/10



Three phase single switch RTRD speed controllers

Type	RTRD-2	RTRD-4	RTRD-7	RTRD-14
Voltage [V]	400	400	400	400
Current [A]	2	4	7	14
Protection level	21	21	21	21
Height [mm]	284	323	323	290
Width [mm]	240	270	270	450
Depth [mm]	132	173	172	174
Voltage levels U[V]	85 / 145 / 190 / 240 / 400	85 / 145 / 190 / 240 / 400	85 / 145 / 190 / 240 / 400	85 / 145 / 190 / 240 / 400



Single phase double switch ARWU speed controllers

Type	ARWU-1,5	ARWU-3	ARWU-5	ARWU-7	ARWU-10
Voltage [V]	230	230	230	230	230
Current [A]	1,5	3	5	7	10
Protection level	54	54	54	54	54
Height [mm]	305	305	305	305	425
Width [mm]	200	200	200	200	300
Depth [mm]	155	155	155	155	175
Voltage levels U[V]	115 / 135 / 155 / 180 / 230	115 / 135 / 155 / 180 / 230	80 / 105 / 135 / 170 / 230	80 / 105 / 135 / 170 / 230	80 / 105 / 135 / 170 / 230



Three phase double switch RUDT speed controllers

Type	RUDT-2T	RUDT-4T	RUDT-7T
Voltage [V]	400	400	400
Current [A]	2	4	7
Protection level	21	21	21
Height [mm]	323	323	323
Width [mm]	270	270	270
Depth [mm]	163	163	163
Voltage levels U[V]	85 / 145 / 190 / 240 / 400	85 / 145 / 190 / 240 / 400	85 / 145 / 190 / 240 / 400



ARW controller

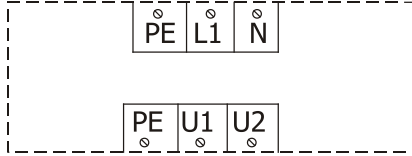

PE-L1-N input voltage (230V AC)
PE,U1,U2 output control voltage

RTRD controller

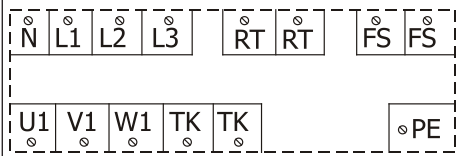

L1-L2-L3 input voltage (400V AC)
U1,V1,W1 output control voltage
TK-TK thermal protection circuit
RT-RT / FS-FS remote on/off (from TP/TPP thermostat)

ARWU controller

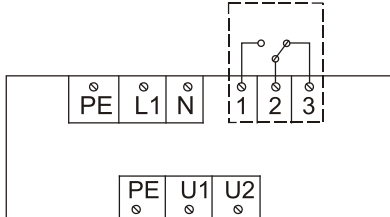

PE-L1-N input voltage (230V AC)
PE,U1,U2 output control voltage
1-2-3 External contact switch 230V/2A AC

Fig. 16 RUDT controller

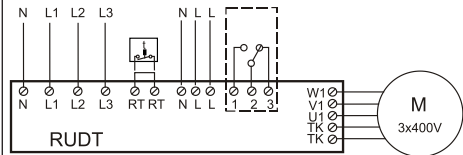

L1-L2-L3 input voltage (400V AC)
U1,V1,W1 output control voltage
TK-TK thermal protection circuit
RT-RT / FS-FS remote on/off (from TP/TPP thermostat)
1-2-3 External contact switch 230V/2A AC

- WS service switch

WS service switch is used to switch the fan motor off for the period of servicing and maintenance. The WS service switch is a safety element that prevents the fan motor from accidental switch-on during in the course of servicing and maintenance

Type	WS-3	WS-6	
Poles	3-poles	6-poles	
Supply voltage circuit switch	single and three phase	three phase	
Rated continuous current	25A	25A	
Protection level	IP65	IP65	

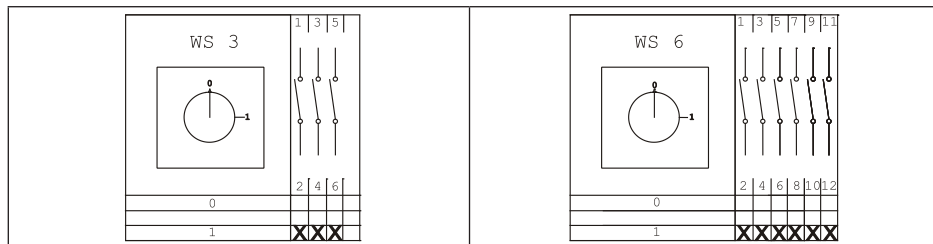

Table 1 Selection of automatic control for WDV-...-T three-phase fans

Fan type	WDV						
	-31	-35	-40	-45	-50	-56	-63
ZS-.../1 control box	●	●	●	●	●	●	●
Transformer speed controller RTRD / RUDT	2	2	2	2	4	7	7
F/ZS inverter	●	●	●	●	●	●	●
TP/TPP indoor thermostat	●	●	●	●	●	●	●
Humidistat TW	●	●	●	●	●	●	●
Air pollution thermostat TZ	●	●	●	●	●	●	●
Programmable timer ZG	●	●	●	●	●	●	●
Service switch WS-6	●	●	●	●	●	●	●

Table 2 Selection of automatic control for WDV-...-J single-phase fans.

Fan type	WDV-, WDH-				
	-31	-35	-40	-45	-50
ZS-.../1 control box	●	●	●	●	●
Transformer speed controller ARW / ARWU	1,2	3	3	7	10
Programmable timer ZG	●	●	●	●	●
TP/TPP indoor thermostat	●	●	●	●	●
Humidistat TW	●	●	●	●	●
Air pollution thermostat TZ	●	●	●	●	●
Service switch WS-3	●	●	●	●	●

12. DEVICE COMMISSIONING

Commissioning of the fan should be carried out by properly qualified personnel only. Before the commissioning check the following:

- » the fan for correct mounting,
- » the electrical connection for correct execution according to electrical diagram,
- » the enclosure for the presence of any foreign particles,
- » the impeller for free rotation without rubbing the fan inlet funnel.

Turn the fan on for few seconds and observe the direction of rotation to check compliance of the fan rotor rotation direction of with the direction indicated by arrow on the cover of the fan.

Once the above works are completed, turn the fan on and observe if there is no vibrations and noise emitted by the impeller. Moreover, during the first commissioning of the fan it is advisable to measure the starting current consumed by the motor. If the current is lower than the rated current, the fan can be considered fit for further use.



If any problems and disturbances arise during the commissioning, switch the power off and contact the supplier or the JUWENT service department.

13. REPAIR, MAINTENANCE AND WITHDRAWAL FROM USE

The fans are intended for continuous operation.

At least once a year check the condition of the fan motor (the motor bearings require no regular lubrication) and, if necessary, remove the defects found according to the motor manufacturer instructions.

Depending on the degree of air pollution, and no less than once a year, clean the fan impeller from any dust and dirt.

Fan bodies in the lower part are equipped in the outflow holes. You should check and if necessary clean above holes.



All maintenance and repair works should be carried out with voltage off.



Use of high-pressure washers is not admissible.

Once the device is withdrawn from use, handle it to a proper waste treatment plant.

14. REMOVING MALFUNCTIONS

Description of malfunction	Possible causes of malfunction	Measures of prevention/removal
Fan won't work	Incorrect connection to power supply	Check for proper connection to power supply.
	Locked impeller	Remove cause of locking
	Damaged motor	Report at JUWENT service department
Low fan performance	Incorrect impeller rotational direction (not in accordance with marking on fan enclosure)	Change polarity of power supply connection
	Contaminated fan inlet grate	Clean inlet grate
Fan high vibrations	Incorrect fan - roof base or roof base - fan connection.	Check for correct connections
	Contaminated or damaged impeller	Remove impeller contaminations. Report any impeller damages at JUWENT service department
Fan operates with excess noise, knocks	Plays on connections between fan elements or on connection between fan and roof base	Remove plays on connections by tightening bolts and screws
	Rubbing between impeller and enclosure	Report at JUWENT service department
	Damaged motor bearings	
Activation of motor overload protections	Damaged or worn bearings.	Report at JUWENT service department
	Damaged motor windings (break, overheat). Damaged circuit-breaker or protection system.	
	Incorrectly set protection relay. Loss of one of supply phases	

15. INFORMATION

As to all issues concerning the roof fan please contact JUWENT Production Plant or our Representatives

III. WARRANTY TERMS AND CONDITIONS

1. JUWENT Szymański, Nowakowski General Partnership, headquartered in Ryki at 31 Lubelska Str., hereinafter referred to as the Warrantor, grants the Customer a warranty of proper operation of the unit with reservation of the requirement of its use in accordance with the conditions determined in the instruction manual and the terms and conditions specified below.
2. The warranty has been granted for a period of 24 months from the purchase date demonstrated in this warranty document with a possibility of its special extension according to a separate agreement and specified in the Special Warranty Terms and Conditions.
3. The warranty covers the removal of technical defects of the unit arisen as a result of its use in accordance with the instruction manual, revealed within the warranty period. The warranty provisions are valid in the territory of the Republic of Poland.
4. By virtue of the granted warranty the Warrantor is not liable for the loss of expected profits and costs resulting from a periodical impossibility of the use of the unit incurred by the Customer.
5. To realize the Customer's rights resulting from the warranty it is required to deliver the claimed unit with the warranty document to the Warrantor at his expense.
6. The claimer delivers the unit in an original factory packing, in case there is no factory packing the claimed unit should be delivered by the Customer for the repair in a way ensuring a safe transport. The risk of accidental damage of the unit during the transport burdens always the party that dispatches the parcel.
7. The defects revealed with the warranty period will be removed by the Warrantor free of charge. A method selection of the realization of obligations resulting from the warranty granted to the Customer belongs to the Warrantor that may remove a defect by the repair or the replacement of the damaged subassembly or by the replacement of the unit. The property of the unit withdrawn from service and / or defective subassemblies is transferred to the Warrantor.
8. The warranty is extended by a period for which the Customer has been deprived of a possibility to use the unit.
9. The Warrantor will make efforts that the repair is executed without further delay within the time-limit of up to 14 working days from the delivery date of the unit. In reasonable cases of which the Customer will be informed by the Warrantor, this time-limit may be extended, e.g. by the time of provision import or when there is a necessity to execute an expertise or laboratory tests in specialized institutions.
10. The Warrantor is liable exclusively for the defects inherent in the sold unit. The damages arisen after its sale for other reasons are not covered by the warranty, in particular:
 - a) mechanical damages (including also damages caused by microparticles occurring in the working environment of the unit), thermal damages, chemical damages and aleatory damages or damages caused by the atmospheric factors,
 - b) damages occurred as a result of non-observance of typical rules or the rules required by the instruction manual related to the operation and mounting of the unit or the use of the unit against the intended use and other damages caused by the Customer's activity or omission,
 - c) damages being a result of defective operation of the system in which the unit has been built or used,
 - d) damages occurred as a result of non-execution of the actions to which the Customer has been obliged in accordance with the instruction manual, e.g. periodical cleaning, maintenance, adjustment, etc.,
 - e) damages occurred due to the use of materials or parts subject to a normal operational wear other than the materials recommended by the Warrantor in the instruction manual,
 - f) damages being a result of use of power supply of the unit (of the system in which this unit functions) incompliant with the standard, and in case the unit is also supplied with water, damages being a result of use of water (supply water and / or boiler water) with parameters other than the parameters foreseen in the valid standard (PN-93/C-04607),
 - g) damages occurred as a result of operation and / or maintenance of the unit in a way incompliant with the instruction manual and / or executed by the unauthorized persons.
11. The warranty does not cover as well:
 - a) activities executed by the Customer in accordance with the recommendations included the instruction manual of the unit within the framework of normal maintenance and inspections,
 - b) travel and work costs of the Warrantor's service or an entity delegated by the Warrantor in case when a warrant call turns out to be groundless.
12. An annotation made by a trained employee in the Inspection and Maintenance Document of the unit is a confirmation of time-limit holding and range of activities foreseen for the maintenance of the unit.
13. The Warrantor is not liable for damages incurred by the Customer or third parties caused the run of the unit occurred in particular as a result of non-observance of the afore-mentioned terms and conditions by the Customer.
14. In case the service works are executed by the Warrantor at the place where the unit is mounted, the Customer will make available a free access to the rooms where the units are located to the Warrantor.
15. In case the units are mounted at the height making an access from the floor surface impossible, the Customer will ensure the scaffolding compliant with the OHS regulations or mobile lifting platforms and vertical transport equipment.
16. The equipment from the electric and / or hydraulic system is disassembled by the Customer.
17. The claims should be lodged at the Warrantor's address in writing / by fax / email using a service notification form.
18. The Warrantor refuses to execute the warranty activities (periodical service works or repair) in case the price for the unit or previous service work is not paid for the benefit of the Warrantor.

DATE OF SALE

STAMP AND SIGNATURE

Special Warranty Terms and Conditions:

Warranty period extension up to months.

Other:

STAMP AND SIGNATURE

TYPE OF UNIT:	
FACTORY NUMBER:	
YEAR OF PRODUCTION:	

IV. UNIT STARTUP REPORT

Date of startup	Executor of startup stamp / name and signature	Motor current [A]	User's representative stamp / name and signature	Remarks

V. INSPECTION AND MAINTENANCE DOCUMENT

Date of inspection	Executor of inspection stamp / name and signature	Service activity range	Remarks

* Inspection of the unit in accordance with the section "Repair and Maintenance" in the instruction manual

VI. SERVICE NOTIFICATION

Date:

Notification type WARRANTY POST-WARRANTY PAID

Unit's user (name)	
Contact person	
User's address	
Phone, fax, and email	
Type of unit	
Serial No.	
Year of production	
Startup executed by	

Description of defect:

NOTE: AFTER COPYING AND FILLING IN SEND THE NOTIFICATION BY FAX OR EMAIL TOGETHER WITH A COPY OF THE STARTUP REPORT.

JUWENT Company accepts notifications filled legibly and completely.

When the lodged claim is not justified, the claimer will be burdened with service costs.

Date of warranty issue

Order No.

(company's stamp)

.....

.....

VII. LIST OF SUBASSEMBLIES INSTALLED IN THE UNIT

No.	Name of subassembly	*)
1	Laminate casing	
2	Three phase AC fan motor	
3	Single phase AC fan motor	
4	Three phase EC fan motor	
5	Single phase EC fan motor	

*) - mark proper box corresponding with the equipment variant