



JUWENT

Szymański, Nowakowski Sp. j.
31 Lubelska Str., 08-500 Ryki
phone +48 81 883 56 00
POLAND

UVERS UNIT HEATERS



- I. CONTACTS
- II. ORIGINAL OPERATING INSTRUCTIONS
- III. WARRANTY CONDITIONS
- IV. STARTUP REPORT
- V. INSPECTION AND MAINTENANCE CHART
- VI. SERVICE REQUEST FORM
- VII. LIST OF COMPONENTS INSTALLED IN THE PRODUCT



Read the instruction manual carefully before starting work.

I. CONTACTS



Szymański, Nowakowski General Partnership
31 Lubelska Str., 08-500 Ryki
phone +48 81 883 56 00,
POLAND

Export department
mob.+48 502 087 841
mob.+48 664 465 243
export@juwent.com.pl

II. ORIGINAL OPERATING INSTRUCTIONS

UVERS UNIT HEATERS

TABLE OF CONTENTS

1. INTENDED USE	5
2. DESIGNATIONS	5
3. DESCRIPTION	6
4. TECHNICAL DATA	6
5. TRANSPORTATION	7
6. SAFETY RECOMMENDATIONS	8
7. INSTALLATION	9
8. WATER SYSTEM - UVERS W	10
9. REFRIGERATION SYSTEM - UVERS DX	11
10. ELECTRICAL WIRING	11
11. CONTROLS	13
13. START-UP	18
12. REPAIR, MAINTENANCE AND DECOMMISSIONING	19
14. TROUBLESHOOTING	20
15. INFORMATIONS	20

1. INTENDED USE

UVERS W unit heaters are designed to be fed with hot water from low temperature heat sources such as heat pumps or gas-fired boilers. They can also be fed with chilled water to provide cooling. UVERS DX unit heaters are suitable for use alongside air-to-air heat pumps. Thanks to the reversible system, they can also provide a cooling function.

The unit heaters are designed for heating and cooling areas such as:

- » factory floors,
- » workshops,
- » warehouses,
- » sports and entertainment halls.



Unit heaters cannot be used in areas with relative humidity above 95% and air dust concentration above 3mg/m³.



UVERS W units can be fed with water at a maximum temperature of up to 150°C and an operating pressure of up to 1.5MPa.



Unit heaters are suitable for vertical operation with a maximum inclination from the vertical plane of 25°.



UVERS DX units can be fed by R410A refrigerant; working pressure up to 3.5MPa.



When the unit heater is operating in cooling mode, condensation may be entrained by the air stream. Follow the instructions in this manual.

2. DESIGNATIONS

Unit heater	UVERS W	-1	-III	-EC
Size	1; 2			
Number of coil rows	II; III			
Fan type	AC; EC			
Unit heater	UVERS DX	-1	-III	-EC
Size	1; 2			
Number of coil rows	III			
Fan type	AC; EC			

3. DESCRIPTION

The unit heater consists of:

- » **axial fan** with AC or EC single phase motor;
- » **coil** made of copper tubes with an external diameter of 12 mm and aluminium fins with fin spacing $s=2.4$ mm.

UVERS W is available with two types of coils: 2 or 3 row coils adapted to work with low temperature heat sources and 3 row coils suitable for cooling function as they can be fed with chilled water. UVERS DX is only available with a 3-row coil suitable to work with heat pumps using R410A refrigerant in a two-pipe reversible system.

- » **casing** with single-row outlet grille which helps to increase the air throw.

Accessories:

- » specially designed wall mounting bracket that allows the position of the unit heater to be adjusted at an angle of $\pm 45^\circ$ in the horizontal plane and at an angle of 25° plane;
- » drip tray for collecting the condensate generated during the cooling process.

4. TECHNICAL DATA

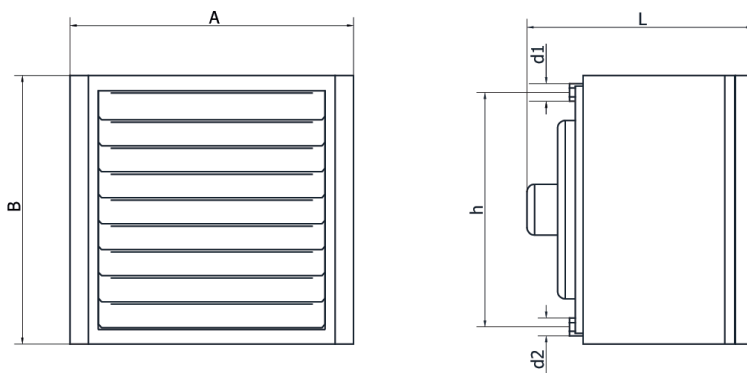

Unit heater size	UVERS W-1		UVERS W-2	
A (mm)	556		677	
B (mm)	527		686	
h (mm)	460		620	
Number of coil rows	II	III	II	III
d₁ d₂	3/4" 3/4"	3/4" 3/4"	3/4" 3/4"	1" 1"
Volume (dm³)	1.5	2.0	2.4	3.2
AC	L (mm)	445		461
	weight (kg)	26	28	41
EC	L (mm)	350		423
	weight (kg)	24	26	46

Unit heater size		UVERS DX-1	UVERS DX-2	
A (mm)		556	677	
B (mm)		527	686	
h (mm)		460	620	
Number of coil rows		III	III	
d_1, l, d_2		12 22	12 28	
Volume (dm ³)		2.0	3.2	
AC	L (mm)	445	461	
	weight (kg)	29	49	
EC	L (mm)	350	423	
	weight (kg)	27	54	
AC fans parameters				
Supply voltage (V)		230	230	
Motor power (W)		140	250	
Current (A)		0.65	1.2	
Speed (rpm)		1400	1350	
IP		54	54	
Operating temperature		60°C	60°C	
EC fans parameters				
Supply voltage (V)		230	230	
Motor power (W)		140	332	
Current (A)		1.45	2.16	
Speed (rpm)		1160	1300	
IP		54	54	
Operating temperature		40°C	70°C	
Noise level				
	UVERS DX-1-AC	UVERS DX-1-EC	UVERS DX-2-AC	UVERS DX-2-EC
Noise level (dB(A))	53	56	62	64

Noise level — sound pressure level taking into account the sound absorption in the room A=100m² and directivity factor Q=2 at a distance of 5 m.

5. TRANSPORTATION

The unit heaters are supplied complete, in cardboard packaging to protect them from dirt and atmospheric influences.

The instruction manual is delivered with the unit heater.

The controls are supplied separately on request.



The unit heaters should be shipped in no more than two layers with padding to prevent mechanical damage.

6. SAFETY RECOMMENDATIONS



The unit heaters should only be used in accordance with the instruction manual.



The start-up, installation, connection, inspection and repair of the unit should be carried out by an authorized contractor, the electrical work should be carried out by a person with the required certificates authorized to carry out electrical work. All maintenance and repair work must be carried out when the power is off.



In the event of a malfunction, immediately disconnect the motor from the power supply and shut off the heating medium supply to the coil.



The unit heater may only be operated with correctly functioning electrical safety devices. It must be permanently connected to an electrical system equipped with a protective (grounding) terminal, a residual current device and a service switch.



Use only original spare parts.



It is forbidden to operate the unit heater with the fan without a protective grille.

Caution!

Failure to install or operate the unit heater in accordance with the operating instructions may result in damage to the unit heater and void the warranty.

Due to its design, the unit heater does not emit any hazardous radiation. Despite the fact that the product has been designed and manufactured in accordance with the standards in force at the time of manufacture, there is an unavoidable risk of injury or damage to health when using the product. This probability is related to the frequency of use, cleaning and repair of the unit heater, the presence of persons in the danger zone and failure to comply with the safety rules set out in the instructions. The severity of physical injury and deterioration in health depends on many conditions which can only be partially anticipated by taking them into account in the design of the equipment and by providing descriptions and warnings in the instructions for use. Therefore, there is a residual risk if the recommendations and instructions are not followed by the operator.

7. INSTALLATION

The walls, ceilings or structural parts of the building to which the brackets or other suspensions of the unit heaters are attached should be of adequate strength. This should be agreed with the building designer.



The supporting structures for the unit heater can be freely designed according to the strength requirements.



If it is necessary to mount the unit on a partition wall, e.g. made of sheet metal, reinforcement should be used to prevent vibrations of the partition wall caused by the operation of the unit heater and an increase in the noise level in the room.



The minimum distance from the wall or ceiling required to ensure free passage of the air to the fan is 30 cm for the UVERS-1 units and 40 cm for the UVERS-2 units measured from the rear face of the unit casing.

Mounting brackets

- » The units can be mounted on the wall using the mounting bracket that is available as an accessory for the UVERS units.
- » It allows the unit heater to be rotated $\pm 45^\circ$ in the horizontal plane and tilted 25° in the vertical plane.
- » The bracket should be fastened to the unit heater with M8 x 60 bolts using spacer sleeves.

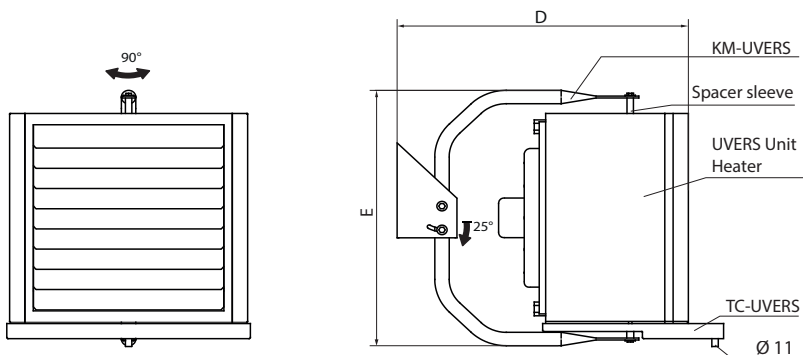

Wall bracket	D (mm)	E (mm)	Bracket weight (kg)	Condensate drip tray	Weight of dip tray (kg)
KM-UVERS-1	682	645	3.1	TC-UVERS-1	2.0
KM-UVERS-2	782	804	3.6	TC-UVERS-2	2.5

- » For units with a cooling function, use a drip tray and position the blades of the outlet grille at a 45° angle to prevent condensation from being carried away.
- » The unit heaters with drip tray must be operated perpendicular to the wall to allow condensation to drain (do not tilt the unit heater!).
- » The condensate drip tray has a drain connection $\text{Ø } 11\text{mm}$.
- » The condensate can be discharged directly to the sewer or via a condensate pump.
- » The drip tray should be installed under the unit heater and fastened to the mounting bracket with an M8 x 60 bolt.

8. WATER SYSTEM - UVERS W



UVERS units with water coils can be fed with water at a maximum temperature 150°C and working pressure up to 1.5MPa.

It is recommended:

- » to connect the bottom connection of the coil to the supply pipe of the heating system and the return pipe to the top connection;
- » to use shut-off valves on the supply and return pipes to allow the unit heater to be removed without draining the heating system.

The solenoid valves should be installed in the supply line upstream of the coil.

Unit heater coils should be vented and drained centrally in the network using air vents and drain valves.



Centralised drainage of the water coil is not possible for ceiling-mounted unit heaters.



Inaccurate venting of the coil may be the reason why the unit heater does not achieve the desired parameters.



The coil connections are not intended to bear the weight of the pipework.

When connecting the pipes to the coil, the connections must be secured against over-tightening and consequent damage to the thread, as shown in the figure below.

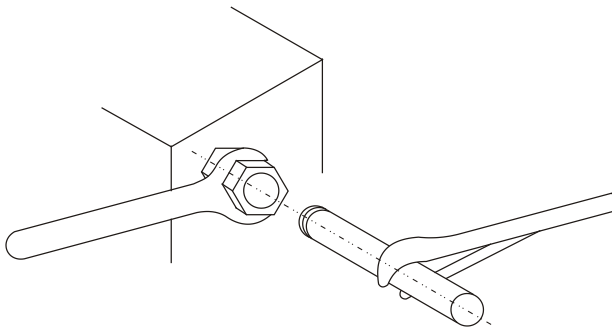

Damage to the coil caused by the above is not covered by the warranty.

9. REFRIGERATION SYSTEM - UVERS DX



UVERS DX units can be fed by R410A refrigerant; working pressure up to 3.5MPa. Use of the DX coil with other operating parameters requires consultation with the manufacturer.



The DX coil is designed to be connected to the refrigeration system by brazing.



After leak and pressure testing, the coil is filled with nitrogen and its connections are blanked off to prevent impurities from entering the coil.



Installation of the DX coils should only be carried out by qualified personnel.



The DX coils are designed for use in reversible system.

During installation, ensure that:

- » the coil is correctly connected taking into account its connection side,
- » the coil is connected to the system in such a way as to avoid bending and torsion of its headers.

The pipework should be designed and installed on supports to minimise transmitted vibration and to avoid stress on the coil connections.

When connecting the pipes, pay attention to the diameter of the coil connection. The suction line should allow the oil to return from the evaporator to the compressor by continuous gravity (minimum slope 1cm/m). If it is not possible, it will be necessary to install a suction siphon at each coil connection.

Soldering/brazing using a socket-type alloy fitting is recommended to join two copper pipes, both to ensure the strength of the joint and to reduce the risk of breakage due to vibration.

- » Pipe sizes should be determined in accordance with good engineering design practice. Before charging refrigerant, the system should be fully pressure tested, checked for leaks and dried to remove moisture.
- » The refrigeration system pressure test should be carried out when the system is complete (all outer and inner units are connected). Use technical nitrogen at 4.2 MPa for the test. The test pressure shall be held for at least 24 hours.
- » Evacuate the refrigeration system in order to remove air and moisture from the inside. Connect a vacuum pump to the system to perform evacuation. It is recommended that the vacuum pump has a minimum flow rate of 4 l/s and a maximum vacuum of -756 mmHg. After switching off the vacuum pump and closing the pressure gauge valves on the system, the vacuum should be maintained continuously.

10. ELECTRICAL WIRING

The electrical wiring and the connection of power to the unit heater must be executed in accordance with relevant requirements of standards and construction regulations.



Electrical connections of the unit heater can only be carried out by an authorized electrician familiar with the instruction manual.

Before connecting, make sure that the mains voltage and frequency as well as protection values are in accordance with the information given on rating plates of unit heaters. In the event of non-

compliance, do not connect the unit. The unit heaters are equipped with single (1~230V/50Hz) motors with internal thermal contacts Tk (routed to the terminal box or permanently connected to the motor control circuit). When making the electrical connection of the fan, ensure that a service switch (WS), overload and short-circuit protection are provided in the control box.



The warranty is void if the required protective devices are not provided and the thermal contact Tk is not connected to the control circuit.

The fan power cable should be routed to the terminal box and fastened to the protection grille or fan mounting brackets using cable ties. Connect the fan thermal contact to the fan power control circuit.

The electrical connection of the motor must be made in accordance with the wiring diagrams in the terminal box.

Example fan wiring diagrams for connecting and control are shown in Figure 1.

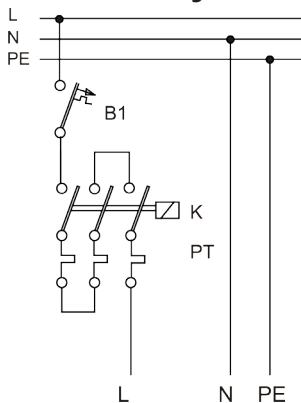

AC fan motor

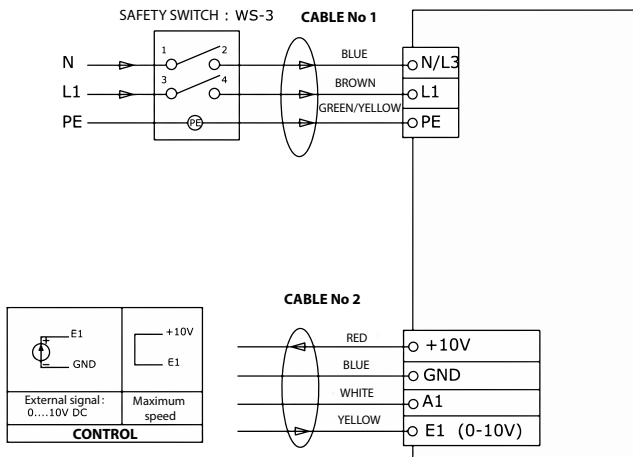

EC fan motor

Fig. 1 Wiring diagrams for fans used in UVERS unit heaters

11. CONTROLS

When the unit heater is operating in cooling mode, condensation may be entrained by the air stream. In such a situation, the air flow should be reduced to the value indicated in the table (the value marked with an asterisk) and the outlet grille blades should be set at an angle of 45°.

The following are the recommended maximum speed controller settings:

- » for UVERS ...1-AC operation with reduced control voltage up to 180 VAC
- » for UVERS ...1-EC operation at speed control signal ~ 8V DC
- » for UVERS ...2-AC operation with reduced control voltage up to 155 VAC
- » for UVERS ...2-EC operation at speed control signal ~ 6V DC

The controls for UVERS DX depend on the heat pumps used with the unit heaters.

The control options should be discussed with your heat pump supplier.

The UVERS W unit heaters can be supplied with:

- **control box:** wall-mounted in a closed enclosure (equipped with: main switch, overcurrent and short-circuit protection devices, indicators), designed to ensure the operation of control system.



A single control box can control a number of unit heaters with one thermostat in AUTOMATIC / MANUAL mode.

The control box (1~230V/50Hz) should be supplied from the main switchboard equipped with a main switch and residual current device.

When controls are ordered with the unit heaters, wiring diagrams of the unit heaters and controls are also provided.

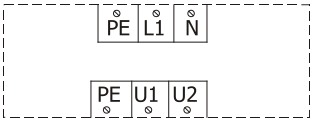

Example control wiring diagrams for unit heaters with single-phase motors are shown in Figures 2 through 6.

- **Fan speed controller:** ARW (1~230V/50Hz) five-speed transformer enables air flow and heat output control. Fan speeds are manually selected.

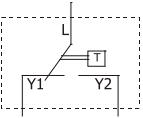

Speed controller type	ARW-1.2	ARW-3		
Supply voltage (V)	230	230		
IP	21	21	PE-L1-N Input voltage (230V AC) PE,U1,U2 Output voltage (control voltage)	
Height (mm)	123	173		
Width (mm)	77	90		
Depth (mm)	71	89		

- **Room thermostat:** The TP on/off room thermostat allows the desired room temperature to be set within a range of 8 to 30°C using a rotary knob, while the TPP on/off room thermostat with LCD display allows the desired temperature to be set within a range of 8 to 30°C in day and night mode.

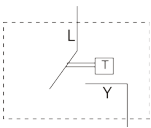

TP or TP/IP65 Thermostat

Supply voltage	24..250V AC	24..250V AC		
Measurement range	8...+30°C	8...+35°C		
Contacts load	6(2)A	10(1.5)A	L-Y1 Heating L-Y2 Cooling	
Protection degree	IP30	IP65		

TPU Thermostat

Supply voltage	24..250V AC	 <p>L-Y Heating and Cooling</p>	
Measurement range	8...+30°C		
Contacts load	6(2)A		
Protection degree	IP30		

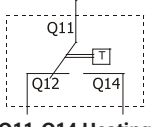

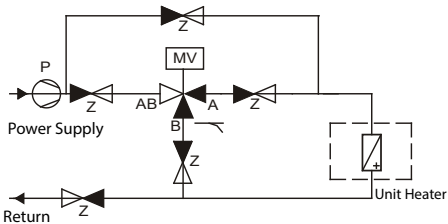

TPP Programmable Thermostat

Supply voltage	2 batteries 1,5V	 <p>Q11-Q14 Heating Q11-Q12 Cooling</p>	
Measurement range	5...+35°C		
Contacts load	5(2)A		
Protection degree	IP30		

-V 3-way Valves : The diverting valves are widely used to control the flow of fluid through the coils. Three-way diverting valves with V20 internally threaded connection (on/off) are used. The valves shall be installed on the supply pipe, the flow is allowed only in the direction pointed out by the arrow on the valve body: AB->A or AB->B.

Symbol	DN	k_{vsr} , m ³ /h	t (°C)	PN	Unit type	
V20	20	3.5	1...110	16	-1 -2	
<p>FITTINGS: Z: cut-off valve: manual P: Circulating pump MV: 3-way control valve controlled by the actuator</p>						

- MV Valve Actuators: designed for direct mounting on valves, providing valve control via modulating 0-10V DC (when used with RT Controller) or on/off control signal (when used with TP or TPP Thermostat). The position of the valve stem (retracted or extended) is proportional to the control signal from the controller or thermostat.

Actuator type	on/off		modulating signal	
Supply voltage	230V AC		24V AC	
Close / open time	180 s		150 s	
Protection degree	IP40		IP43	
	MV+V20 on/off actuator		MV modulating actuator	
				
	L-N Supply voltage 230V AC		Y Input control signal 0...10V DV G0 System neutral G System potential, 24V AC	

- **WS Service Switch:** intended for switching off the fan motor in order to carry out service work. The use of the WS switch prevents unexpected starting of the motor, which could cause a hazard during service work.

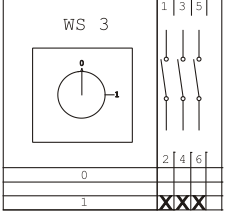
Service switch type	WS-3		
Poles	3-poles		
Supply circuit switch	3-phase		
Continuous rated current	25A		
Protection degree	IP 65		

Examples of wiring diagrams for unit heaters with AC fans.

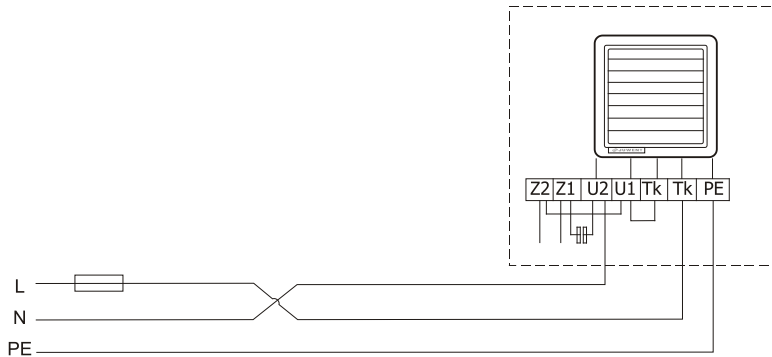

Fig. 2 Wiring diagram for unit heater without controls

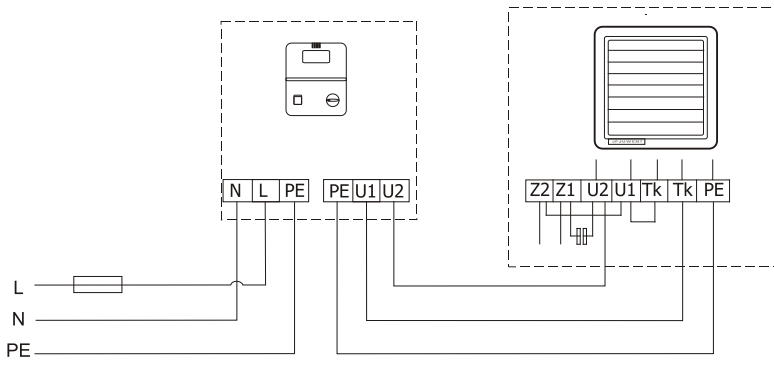

Fig. 3 Wiring diagram for unit heater with speed controller

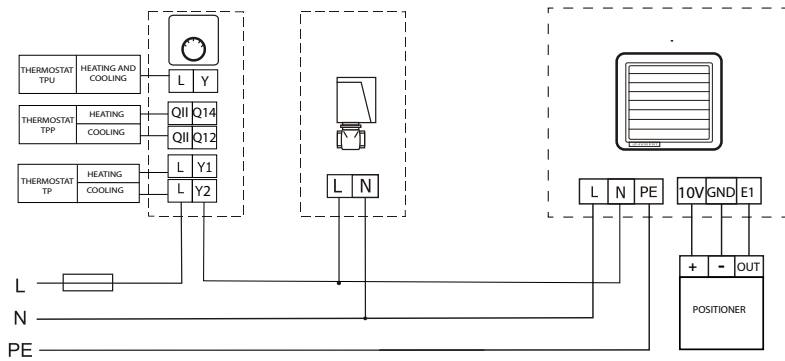

Fig. 4 Wiring diagram for unit heater with controls (thermostat controls speed controller, valve actuator and fan operation)

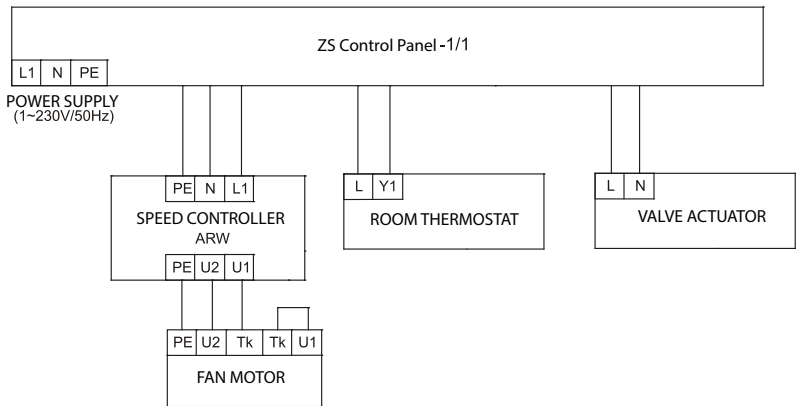

Fig. 5 Wiring diagram for controls without ARW speed controller

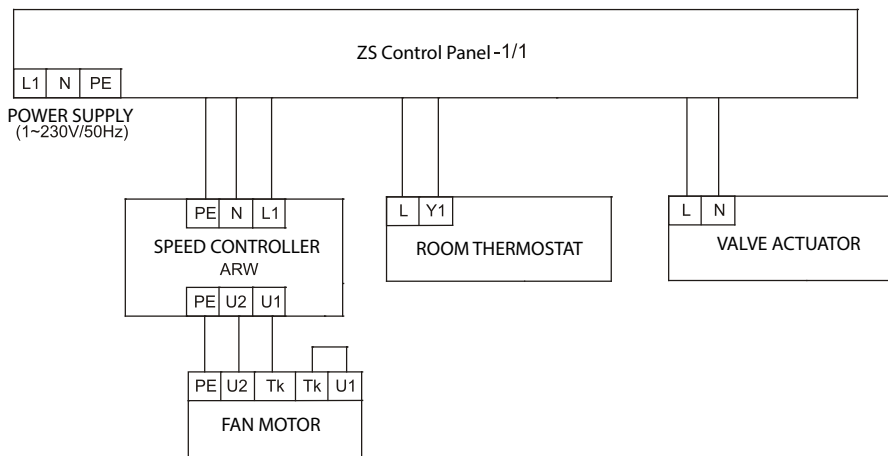

Fig. 6 Wiring diagram for controls with ARW speed controller

Examples of wiring diagrams for unit heaters with EC fans

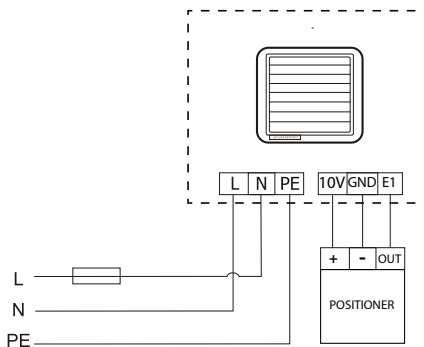

Fig. 7 Wiring diagram for unit heater without controls

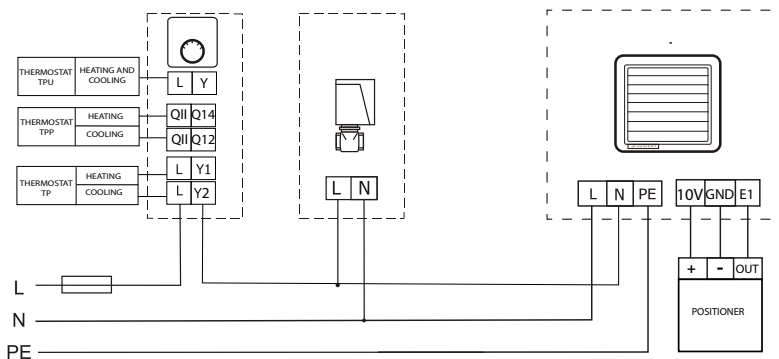

Fig. 8 Wiring diagram for unit heater with controls (thermostat controls valve actuator and fan operation)

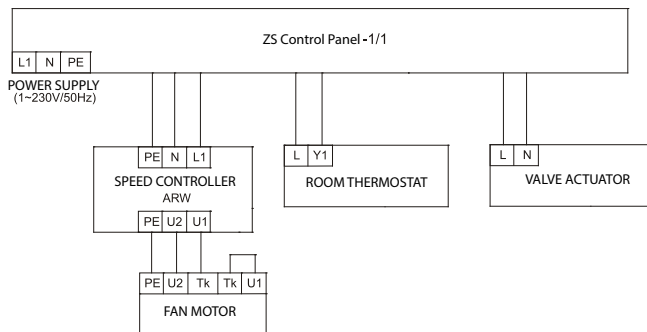

Fig. 9 Wiring diagram for controls

13. START-UP

Before start-up:

- » ensure that the unit heater is properly mounted,
- » check that all the water connections are tight,
- » check that the supply voltage corresponds to that indicated on the rating plate,
- » check up the additional protection of the fan and unit casing,
- » check that the electric motor is correctly connected,
- » check the direction of rotation of the fan.

To turn on the unit heater it is necessary to:

- » open the appropriate valves on the supply and return lines and connect the unit heater to the power supply,
- » adjust the direction and throw of the discharged air using the outlet grille blades. The start-up must be carried out by qualified personnel.

To turn off the unit heater it is necessary to:

- » reduce the water flow to the heating coil (or shut off the feed water supply)
- » The heating system should be designed and the unit heater should be selected taking into account the maximum operating pressure. If necessary, appropriate precautions should be taken to ensure that the value of this pressure is not exceeded.
- » switch off the power supply to the electric motor of the fan.



In case of long standstills of the unit or breaks of heating network operation the heating coil should be drained and the cut-off valves should be closed, if need be.

12. REPAIR, MAINTENANCE AND DECOMMISSIONING

The rolling bearings used in the fan do not require periodic relubrication. However, it is advisable to check the condition of the motor bearings regularly (the fan impeller should rotate freely without excessive play or knocking).

If the operating noise level of the unit heater increases, check that the fan and the entire unit are properly mounted.

The impeller blades should be cleaned with a damp cloth after removing the protective grille in order to prevent it from becoming unduly dirty and therefore unbalanced.

Do not use pressure washers to clean the fan.

In the event of a malfunction or faulty operation of the unit heater, contact the contractor or our service department.



All repair and maintenance work should be carried out with the power supply disconnected. The units heaters should also be protected against being accidentally switched on by others.

The coils should be checked regularly for dust accumulation. If excessive, blow out the coils using compressed air.



Excessive dirt build-up on the coil reduces heat transfer efficiency and airflow.

When the equipment is decommissioned, it should be disposed of at special collection points for recycling.

14. TROUBLESHOOTING

Description of the problem	Possible cause	Solution
leaking coil	mechanical damage to the coil (can easily occur if carelessly connected to the heating/cooling system)	always use two wrenches when connecting the coil to the heating/cooling system
	exceeding of the permissible water parameters for heating	the heating system should be fitted with safety devices to prevent the water pressure and temperature from being exceeded
	frozen coil	use an anti-freeze thermostat, non-freezing heating fluids, or drain the water out of the coil if it is not expected to operate for a long period and there is a risk of freezing
	the unit heater is used in an aggressive environment	
too loud operation of the unit	minimum distance from the wall or ceiling is not maintained	use distances recommended in the instruction manual
	improper direction of rotation of the fan	execute a proper electric connection
	improper parameters of the mains	use the unit only when the parameters of the mains and the unit are compliant
	air outlet is blocked by outlet grid louvres	avoid a significant closing of outlet grid louvres at high speed ratios
	fan vibrations, the blades rub against fixed elements not centric fastening of the fan in its bearing plate	check up the correctness of the fan and fastening reliability of other elements of the unit
fan does not work	incorrect or unreliable electric connections	check up or correct: 1) compliance of electric connections according to the diagrams specified in the instruction manual 2) reliability of terminal connections 3) parameters of the mains
	improper parameters of the mains (lack of three phases in three-phase motors)	
	fan motor is damaged	
	fan operation control elements are damaged	
ARW speed controller does not work	electrical connections are incorrect (loose terminal block connections)	check up or correct: 1) compliance of electric connections according to the diagrams specified in the instruction manual 2) reliability of terminal connections 3) parameters of the mains
	one controller is connected to more than one unit heater	
Actuator does not actuate the valve into the open position	The thermostat is not working correctly (there is no characteristic clicking sound when switching)	check up or correct: 1) compliance of electric connections according to the diagrams specified in the instruction manual 2) reliability of terminal connections 3) parameters of the mains 4) that the actuator has responded to the electrical impulse. If the actuator is found to be damaged, a claim should be made for the defective component.
Room thermostat sends no signal	more than one unit heater is connected directly to the thermostat (a greater number may overload the thermostat)	check up or correct: 1) compliance of electric connections according to the diagrams specified in the instruction manual 2) reliability of terminal connections 3) parameters of the mains 4) if there is no characteristic clicking sound, the thermostat has been mechanically damaged and a complaint should be made
	location of the thermostat in the room	

15. INFORMATIONS

In the event of any queries or doubts regarding the unit heaters, please contact the JUWENT company or one of our representatives.

III. WARRANTY CONDITIONS

1. JUWENT Szymański, Nowakowski Sp. j. with its registered office in Ryki, at 31 Lubelska Str., hereinafter referred to as the Warrantor, provides a warranty for the product manufactured by it, provided that the product is used in accordance with the conditions set out in this manual and with the following provisions.
2. The warranty is granted for a period of 24 months from the date of purchase stated in this warranty document with the possibility of its special extension according to a separate agreement and specified in the Special Guarantee Conditions.
3. The warranty covers the removal of technical defects of the product caused by its use in accordance with the user's manual, which appear within the warranty period. The warranty terms are valid in the Republic of Poland.
4. On the basis of the granted warranty, the Warrantor shall not be liable for the loss of expected profits and costs incurred by the Buyer as a result of periodic inability to use the product.
5. In order for the Buyer to exercise its rights under the warranty, it is necessary for the Buyer to return the defective product to the Warrantor at the Buyer's expense, together with the Warranty Card.
6. The Claimant must deliver the product in the original factory packaging or, if there is no factory packaging, the Claimant must deliver the product for repair in a way that ensures safe transport. The risk of accidental damage to the product during transport is always borne by the party who sends the parcel.
7. Defects discovered during the warranty period will be remedied free of charge by the Warrantor. The choice of the method of performance of the obligations arising from the warranty granted to the Buyer is the responsibility of the Warrantor, who may remedy a defect by repairing or replacing the damaged component or by replacing the Product. The replaced product and/or defective components become the property of the Warrantor.
8. The warranty is extended by the period during which the Buyer was prevented from using the product.
9. The Warrantor will endeavour to carry out the repair without delay within a period of up to 14 working days from the date of delivery of the Product. This period may be extended in reasonable cases, of which the Warrantor shall inform the Buyer, for example, by the time of importation of the components or if there is a need to carry out an expertise or laboratory tests in specialised institutions.
10. The Warrantor is solely liable for defects in the products sold. The warranty does not cover damage caused after the sale for other reasons, in particular:
 - a) mechanical damage (including damage caused by microparticles present in the working environment of the product), thermal damage, chemical damage and damage caused by accidental or atmospheric factors,
 - b) damage caused as a result of failure to comply with typical rules or those required by the instruction manual relating to the operation and installation of the product, or use of the product other than for its intended purpose, and other damage caused by the Buyer's actions or omissions,
 - c) damage caused by incorrect operation of the system in which the product is installed or used,
 - d) damage caused by failure to carry out the operations that the Buyer is obliged to carry out in accordance with the instructions, such as regular cleaning, maintenance, adjustment, etc,
 - e) damage caused by the use of materials or parts subject to normal wear and tear other than those recommended by the Warrantor in the instructions contained in the manual,
 - f) damage caused by using the power supply for the product (or the system in which the product operates) that does not comply with the standard and, if the product is also supplied with water, damage caused by using feed water with parameters other than those specified in the valid standard (PN-93/C-04607),
 - g) damage caused as a result of operation and/or maintenance of the product in a manner not in accordance with the instruction manual and/or carried out by unauthorised persons.
11. The warranty also excludes:
 - h) activities performed by the Buyer under normal maintenance and inspection in accordance with the product's manual,
 - i) travel expenses of the Warrantor's service technicians or those of a company appointed by the Warrantor in the event that the service request proves to be unjustified.
12. To confirm compliance with the conditions and scope of activities foreseen for the maintenance of the product, records are made by qualified personnel in the product's Inspection and Maintenance Chart.
13. The Warrantor shall not be liable for any loss or damage suffered by the Buyer or any third party as a result of failure to comply with the above conditions.
14. If the Warrantor carries out servicing at the place where the Product is installed, the Buyer shall grant the Warrantor free access to the premises where the product is located.
15. For products installed at a height that cannot be accessed from the ground, the Buyer must provide scaffolding or mobile elevated work platforms and lifting equipment that complies with health and safety regulations.
16. Disconnecting the product from the electrical and/or hydraulic system is the responsibility of the Buyer.
17. Complaints must be made in writing/faxing/emailing to the Warrantor's address using the Service Request Form.
18. The Warrantor will refuse to perform any warranty service (periodic maintenance or repair) in the event of non-payment to the Warrantor for the product or previous service.

DATE OF SALE

STAMP AND SIGNATURE

Special Warranty Terms and Conditions:

Warranty period is extended up to months.

Other:

STAMP AND SIGNATURE

PRODUCT TYPE:	
SERIAL NUMBER:	
YEAR OF MANUFACTURE:	

IV. STARTUP REPORT

Date of start-up	Start-up provider Stamp / Surname and Signature	Motor current [A]	User's representative Stamp / Surname and Signature	Remarks

V. INSPECTION AND MAINTENANCE CHART*

Date of inspection	Inspection provider Stamp / Surname and Signature	Scope of works	Remarks

* Inspection should be carried out in accordance with the 'Repair and maintenance' section of the instruction manual.

VI. SERVICE REQUEST FORM

Date of completion:

Service type WARRANTY POST-WARRANTY PAID

User of the product (name)	
Contact person	
User's address	
Telephone, fax and e-mail	
Product type	
Serial No	
Year of manufacture	
Start-up carried out by	

Description of defect/damage:

NOTE!

ONCE COPIED AND COMPLETED, FAX OR E-MAIL THIS SERVICE REQUEST TOGETHER WITH A COPY OF THE START-UP REPORT.

The JUWENT company will only accept requests that are legible and complete.

In the event of an unjustified complaint, the complainant will be charged for the service.

Date of warranty issue

Order No.

(Company Stamp)

.....

.....

VII. LIST OF COMPONENTS INSTALLED IN THE PRODUCT

No	Component name	*)
1	axial fan with single phase motor	
2	1-row fin coil	
3	2-row fin coil	

*) - tick the appropriate box according to the version of the product