



Szymański, Nowakowski General Partnership  
31 Lubelska Str., 08-500 Ryki  
phone +48 81 883 56 00, fax +48 81 883 56 09  
POLAND

## STEAM HEATERS NP AND P



- I. CONTACTS
- II. ORIGINAL INSTRUCTION MANUAL
- III. WARRANTY TERMS AND CONDITIONS
- IV. UNIT STARTUP REPORT
- V. INSPECTION AND MAINTENANCE DOCUMENT
- VI. SERVICE NOTIFICATION



**Please read this instruction manual carefully before beginning any work.**

RYKI 2015  
ISSUE 1 EN

## I. CONTACTS



Szymański, Nowakowski General Partnership  
31 Lubelska Str., 08-500 Ryki  
phone +48 81 883 56 00, fax +48 81 883 56 09  
POLAND

**Export department**  
mob.+48 502 087 841  
mob.+48 664 465 243  
export@juwent.com.pl

## II. ORIGINAL INSTRUCTION MANUAL

### STEAM HEATERS NP AND P

# TABLE OF CONTENTS

1. INTENDED USE	5
2. DESIGNATIONS	5
3. DEVICE DESCRIPTION	5
4. TECHNICAL DATA	6
5. TRANSPORT	6
6. SAFETY RECOMMENDATIONS	7
7. INSTALLATION	7
8. REPAIR, USE, MAINTENANCE AND WITHDRAWAL FROM USE	8

## 1. INTENDED USE

Frame heaters are used for air heating in ventilating or industrial installations



The air being heated must not contain any factors causing early corrosion of the aluminium ribbing and steel parts.

## 2. DESIGNATIONS

Frame steam heater

Type	NP; P
Size	1 - 12
No. of rows	II lub III, II+II=IV, II+III=V
Steam pressure	0,01; 0,05; 0,1; 0,2; 0,4; 0,6; (MPa)

## 3. DEVICE DESCRIPTION

Heaters are manufactured as a single-, two-, or three-row.

Standard dimensions a x b (fig.):

- » for heater type P are: from 0.42 up to 1.82x1.81 [m],
- » for heater type NP are: from 0.315 up to 2x2 [m].



Heaters of any size can be delivered as agreed with the manufacturer.

The applied design allows for combining the heaters into sets of IV, V, or more rows.

Each heater comprises:

- » internal frame with collars adjusted for connecting to the ductwork ;
- » heating elements made of bimetallic highly-ribbed steel tubes with aluminium ribbing rolled in a spiral way;
- » collectors with connectors are adjusted for connecting to the system by welding or collars.

As a standard, the heating elements are made of tubes with inner diameter  $d = 21.4$  mm, outer diameter of ribs  $D = 58$  mm and rib spacing  $s = 2.8$  or 5 mm.

## 4. TECHNICAL DATA

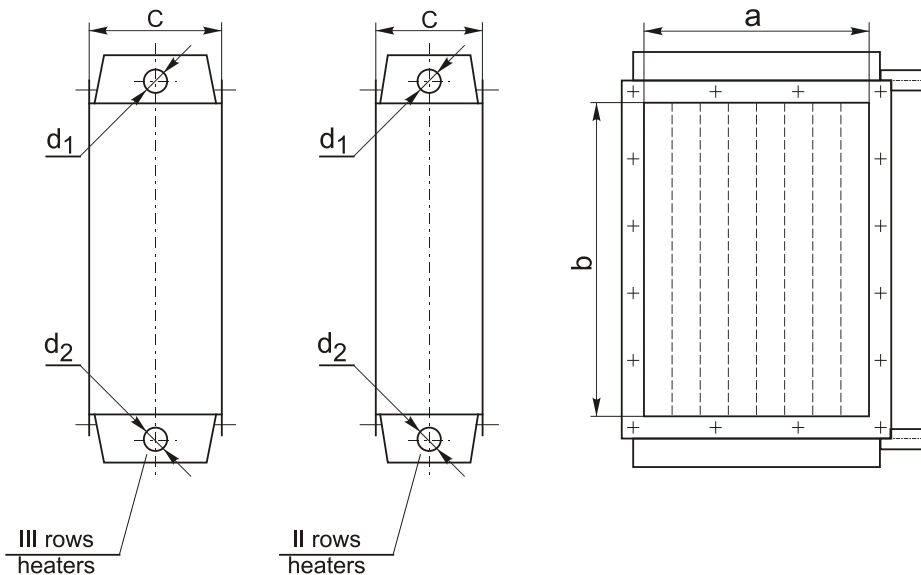

Standard for type "P":	$a = 0.42$ up to $1.82$ [m]	for II rows $c=170$
	$b = 0.48$ up to $1.81$ [m]	for III rows $c=235$
Standard for type "NP":	$a = 0.315$ up to $2.0$ [m]	for II rows $c=160$
	$b = 0.315$ up to $2.0$ [m]	for III rows $c=200$



In the standard manufacture the heaters are supplied with steam pressure of 0.01 up to 0.6 MPa. The steam pressure above 0.6 MPa – to be agreed with the manufacturer. Heaters in the standard manufacture must only be operated when upright. It is permitted to use the heater if tilted from the vertical by  $\sim 30^\circ$ . Other operating conditions should be agreed with the manufacturer.



There is a risk of freezing the condensate in the heater in rooms with temperature below  $0^\circ\text{C}$ .

This risk can be limited by using an anti-freeze thermostat.

## 5. TRANSPORT

For transport the heaters should be protected with polyethylene foil. They can be stacked for transport using pads to prevent any mechanical damages. The fin heater is delivered with the Product Book.

## 6. SAFETY RECOMMENDATIONS



The steam heaters should be used in accordance with this instruction manual.



Do not exceed the steam pressure as specified in the order and technical documentation for a given heater.



Proper (safe) operation of the heater depends on correct choice of the equipment, and drop separators in particular (Choice of the equipment is up to the installation designer)

NOTE: If sets of heaters are used, it is advisable to drain each heater individually. This disables condensate accumulations and water hammers within heating spaces. Additionally, installing check valves prevents the condensate retraction from the collector pipe. Example of installed set of heaters is shown in figure.

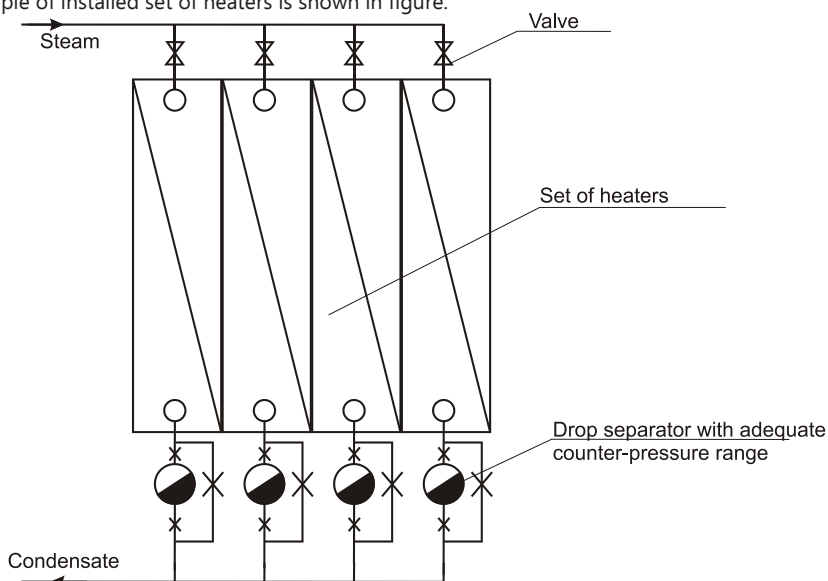

If repairs of the heaters are performed on user's own, the fin should be checked for test pressure in accordance with the valid standard. (Journal of Laws No. 99 item 912 § 58 par. 2.)

## 7. INSTALLATION

The heater basic manufacture includes connectors to be connected to the installation by welding or collars.

The heater is supplied from the top. It is recommended to use cut-off valves before and behind the heater or set of heaters to enable their removal with no need of disabling other heat exchangers supplied from the same system.

Once the heater is installed, do the following:

- » open steam supply (by gradually opening the valve on the supply);
- » check tightness of the connector and the heater;
- » de-aerate;
- » adjust the heating power by:
  - limiting the active heating surface (in multi-row sets of heaters by supplying the steam for some rows only);
  - by-pass some volume of the ventilating air to the outside of the heater and re-mix it.

In the case of long-term idle periods in the heater operation, it is advisable to drain all the water (condensate), and possibly close the cut-off valves.

## 8. REPAIR, USE, MAINTENANCE AND WITHDRAWAL FROM USE

Depending on the level of the air pollution, but no less than once a year, remove dust and dirt from the ribbing with dry, de-oiled compressed air with pressure < 3 bar in the direction opposite to the normal air flow through the heat exchanger.

In order to ensure proper use of steam heaters supply them with steam generated from water meeting the requirements for supply water and boiler water given in Table 1 and Table 2.

Once the device is withdrawn from use, handle it to a proper waste treatment plant.

Table 1 Requirements for supply water

Water quality indicator	Unit	Permissible work overpressure	
		<1 bar	1 - 22bar
General requirements	-	Water – clear, colourless, free of any suspended matter	
pH <sup>1)</sup>	-	>9	
Electric conductivity <sup>1)</sup>	mS/cm	Relevant for boiler water only	
Total rare earth metal salts (Ca <sup>2+</sup> + Mg <sup>2+</sup> )	mmol/l	<0,015	<0,010
General hardness	°dH	<0,1	<0,05
Oxygen	mg/l	<0,1	<0,02
Captured carbon dioxide	mg/l	<25	<25
General iron	mg/l	-	<0,05
Copper	mg/l	-	<0,01
Oxygen uptake (KMnO <sub>4</sub> )	mg/l	<10	<10
Oils, greases	mg/l	<3	<1

Table 2 Requirements for boiler water

Water quality indicator	Unit	Permissible work overpressure	
		<1 bar	1 - 22bar
General requirements	-	Woda klarowna, bezbarwna, bez zawiesin	
pH <sup>1)</sup>	-	8,5-11	10,5-12
Electric conductivity <sup>1)</sup>	mS/cm	<5000	<8000
P alkalinity	mmol/l	<1-8	1-12
Phosphates	°dH	5-20	5-20
Sulphites	mg/l	10-30	10-30
Oxygen uptake (KMnO <sub>4</sub> )	mg/l	<100	<150
Silica	mg/l	-	<150

<sup>1)</sup> Measurement taken at 25°C.



### III. WARRANTY TERMS AND CONDITIONS

1. JUWENT Szymański, Nowakowski General Partnership, headquartered in Ryki at 31 Lubelska Str., hereinafter referred to as the Warrantor, grants the Customer a warranty of proper operation of the unit with reservation of the requirement of its use in accordance with the conditions determined in the instruction manual and the terms and conditions specified below.
2. The warranty has been granted for a period of 24 months from the purchase date demonstrated in this warranty document with a possibility of its special extension according to a separate agreement and specified in the Special Warranty Terms and Conditions.
3. The warranty covers the removal of technical defects of the unit arisen as a result of its use in accordance with the instruction manual, revealed within the warranty period. The warranty provisions are valid in the territory of the Republic of Poland.
4. By virtue of the granted warranty the Warrantor is not liable for the loss of expected profits and costs resulting from a periodical impossibility of the use of the unit incurred by the Customer.
5. To realize the Customer's rights resulting from the warranty it is required to deliver the claimed unit with the warranty document to the Warrantor at his expense.
6. The claimer delivers the unit in an original factory packing, in case there is no factory packing the claimed unit should be delivered by the Customer for the repair in a way ensuring a safe transport. The risk of accidental damage of the unit during the transport burdens always the party that dispatches the parcel.
7. The defects revealed with the warranty period will be removed by the Warrantor free of charge. A method selection of the realization of obligations resulting from the warranty granted to the Customer belongs to the Warrantor that may remove a defect by the repair or the replacement of the damaged subassembly or by the replacement of the unit. The property of the unit withdrawn from service and / or defective subassemblies is transferred to the Warrantor.
8. The warranty is extended by a period for which the Customer has been deprived of a possibility to use the unit.
9. The Warrantor will make efforts that the repair is executed without further delay within the time-limit of up to 14 working days from the delivery date of the unit. In reasonable cases of which the Customer will be informed by the Warrantor, this time-limit may be extended, e.g. by the time of provision import or when there is a necessity to execute an expertise or laboratory tests in specialized institutions.
10. The Warrantor is liable exclusively for the defects inherent in the sold unit. The damages arisen after its sale for other reasons are not covered by the warranty, in particular:
  - a) mechanical damages (including also damages caused by microparticles occurring in the working environment of the unit), thermal damages, chemical damages and aleatory damages or damages caused by the atmospheric factors,
  - b) damages occurred as a result of non-observance of typical rules or the rules required by the instruction manual related to the operation and mounting of the unit or the use of the unit against the intended use and other damages caused by the Customer's activity or omission,
  - c) damages being a result of defective operation of the system in which the unit has been built or used,
  - d) damages occurred as a result of non-execution of the actions to which the Customer has been obliged in accordance with the instruction manual, e.g. periodical cleaning, maintenance, adjustment, etc.,
  - e) damages occurred due to the use of materials or parts subject to a normal operational wear other than the materials recommended by the Warrantor in the instruction manual,
  - f) damages being a result of use of power supply of the unit (of the system in which this unit functions) incompliant with the standard, and in case the unit is also supplied with water, damages being a result of use of water (supply water and / or boiler water) with parameters other than the parameters foreseen in the valid standard (PN-93/C-04607),
  - g) damages occurred as a result of operation and / or maintenance of the unit in a way incompliant with the instruction manual and / or executed by the unauthorized persons.
11. The warranty does not cover as well:
  - a) activities executed by the Customer in accordance with the recommendations included the instruction manual of the unit within the framework of normal maintenance and inspections,
  - b) travel and work costs of the Warrantor's service or an entity delegated by the Warrantor in case when a warrant call turns out to be groundless.
12. An annotation made by a trained employee in the Inspection and Maintenance Document of the unit is a confirmation of time-limit holding and range of activities foreseen for the maintenance of the unit.
13. The Warrantor is not liable for damages incurred by the Customer or third parties caused the run of the unit occurred in particular as a result of non-observance of the afore-mentioned terms and conditions by the Customer.
14. In case the service works are executed by the Warrantor at the place where the unit is mounted, the Customer will make available a free access to the rooms where the units are located to the Warrantor.
15. In case the units are mounted at the height making an access from the floor surface impossible, the Customer will ensure the scaffolding compliant with the OHS regulations or mobile lifting platforms and vertical transport equipment.
16. The equipment from the electric and / or hydraulic system is disassembled by the Customer.
17. The claims should be lodged at the Warrantor's address in writing / by fax / email using a service notification form.
18. The Warrantor refuses to execute the warranty activities (periodical service works or repair) in case the price for the unit or previous service work is not paid for the benefit of the Warrantor.

**DATE OF SALE**

**STAMP AND SIGNATURE**

Special Warranty Terms and Conditions:

Warranty period extension up to ..... months.

Other:

**STAMP AND SIGNATURE**

<b>TYPE OF UNIT:</b>	
<b>FACTORY NUMBER:</b>	
<b>YEAR OF PRODUCTION:</b>	

#### IV. UNIT STARTUP REPORT

<b>Date of startup</b>	<b>Executor of startup</b> stamp / name and signature	<b>User's representative</b> stamp / name and signature	<b>Remarks</b>

#### V. INSPECTION AND MAINTENANCE DOCUMENT

<b>Date of inspection</b>	<b>Executor of inspection</b> stamp / name and signature	<b>Service activity range</b>	<b>Remarks</b>

\* Inspection of the unit in accordance with the section "Repair and Maintenance" in the instruction manual

## VI. SERVICE NOTIFICATION

Date:

Notification type WARRANTY  POST-WARRANTY  PAID

<b>Unit's user (name)</b>	
<b>Contact person</b>	
<b>User's address</b>	
<b>Phone, fax, and email</b>	
<b>Type of unit</b>	
<b>Factory No.</b>	
<b>Year of production</b>	
<b>Startup executed by</b>	

Description of defect:

**NOTE: AFTER COPYING AND FILLING IN SEND THE NOTIFICATION BY FAX OR EMAIL TOGETHER WITH A COPY OF THE STARTUP REPORT.**

JUWENT Company accepts notifications filled legibly and completely.

When the lodged claim is not justified, the claimer will be burdened with service costs.

Date of warranty issue

Order No.

(company's stamp)

.....

.....