



UGW/D Unit Heaters

The units are used for heating or heating and ventilation of industrial shops, storerooms etc. Constructionally, the units are fitted for mounting on walls or structural posts at the height that allows for direct air intake into the heated area. Providing the unit with centrifugal fan allows for the independent operation of the unit or with additional equipment attached with resistance up to 100 Pa. The units may operate as heaters in the recirculation air independently or with a filter attached at the sucking side of the fan, or as heating and ventilation units with air deriving device which allows for drawing fresh air, recirculation air or air mixed at any proportions. The air deriving device may be delivered with or without a filter.

DESCRIPTION

PRODUCT DESCRIPTION

Series of types of the units contains 3 sizes with preserving geometrical similarity which are offered in variants differing in rotational speed of fan, water or steam heating factor, number of heater rows and left or right type. The unit consists of:

- casing;
- highly efficient centrifugal fan with electric motor;
- water or steam heater;
- outlet grate;

All heaters are made of bimetallic pipes i.e. steel core barrel and aluminium ribs rolled outside. Standard water heaters are made of pipes with the following dimensions: inner diameter $d=12,4\text{mm}$, rib outer diameter $D=38\text{mm}$ and ribs spacing $2,8\text{mm}$ and the steam heaters are made of pipes with $d=21,4$ inner diameter, element outer diameter $D=58$ and ribs spacing 5mm . There are left or right types of units offered which means that with the right type the person looking at the outlet grate sees the air inlet on the right. (the picture shows the unit of right type).

WORKING CONDITIONS

The units may be fed with water of $150/70^{\circ}\text{C}$ temperature and pressure of $1,6\text{Mpa}$ max or with steam of pressure up to $0,6\text{Mpa}$. UGW/D 10; 11 units are delivered with three-phase two-gear motors with speed of $\sim 900/1400\text{rpm}$ and on request with single-phase motors (1400rpm). UGW/D 12 units are delivered with three-phase single gear motors with speed of ~ 670 or 900rpm .

UGWD-11-P-B-II

DIMENSIONS

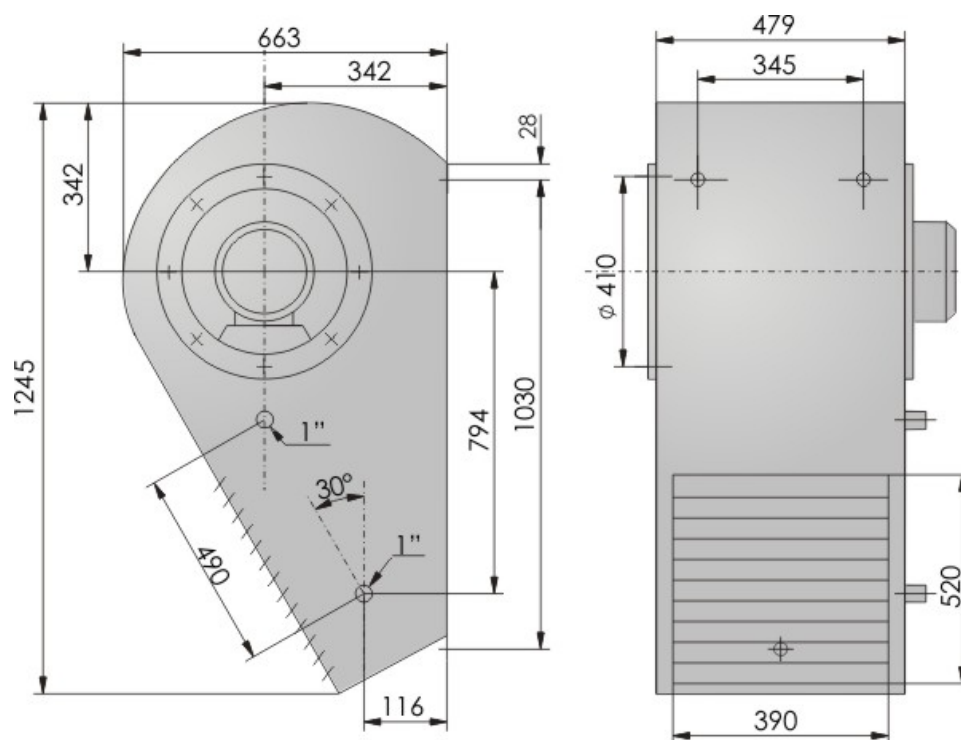

Fan specifications

| | | |
|--------------------------|------|-----------|
| Voltage [V] | 230 | 400 |
| Motor power [kW] | 0,37 | 0,37/0,55 |
| Current [A] | 1,45 | 1,45/1,5 |
| Revolutions [rpm] | 900 | 900/1400 |

Thermal power of units with water heater

| | | |
|-----------------------------------|-----|------|
| Number of heater rows | II | |
| Revolutions [rpm] | 900 | 1400 |
| Air flow [m³/h] | 970 | 1580 |

Thermal power of units with water heater

| Water temp. [°C] | Inflow air temp. [°C] | kW | °C | kW | °C |
|-------------------------|------------------------------|-----------|-----------|-----------|-----------|
| 0,01 | -15 | 34 | 32 | 40 | 23 |
| | 0 | 29 | 40 | 34 | 33 |
| | 15 | 24 | 49 | 28 | 42 |

| | | | | | |
|-------------|------------|----|----|----|----|
| 0,05 | -15 | 35 | 35 | 45 | 26 |
| | 0 | 31 | 44 | 36 | 35 |
| | 15 | 26 | 52 | 30 | 45 |
| 0,1 | -15 | 38 | 37 | 44 | 27 |
| | 0 | 33 | 46 | 38 | 37 |
| | 15 | 28 | 54 | 33 | 48 |
| 0,2 | -15 | 45 | 47 | 52 | 35 |
| | 0 | 40 | 55 | 47 | 44 |
| | 15 | 35 | 63 | 40 | 54 |
| 0,4 | -15 | 53 | 58 | 62 | 43 |
| | 0 | 48 | 66 | 55 | 52 |
| | 15 | 41 | 73 | 50 | 62 |
| 0,6 | -15 | 58 | 65 | 67 | 49 |
| | 0 | 53 | 72 | 63 | 58 |
| | 15 | 48 | 79 | 56 | 68 |

| Operation noise level [dB(A)] | | |
|--------------------------------------|-----------|------|
| Revolutions [rpm] | 900 | 1400 |
| At the distance of 1m | 60 | 70 |
| At the distance of 5m | 56 | 66 |
| Unit weight | | |
| Weight [kg] | 78 | |